

# 9007 Power Tube

## VHF Linear Power Amplifier Tube 33 Kilowatt Peak Sync Output Thru VHF-TV Band

- 14 dB Gain
- High Gain-Bandwidth Products
- Efficient Forced-Air Cooling
- Full Input to 400 MHz
- CERMOLox<sup>®</sup> Construction

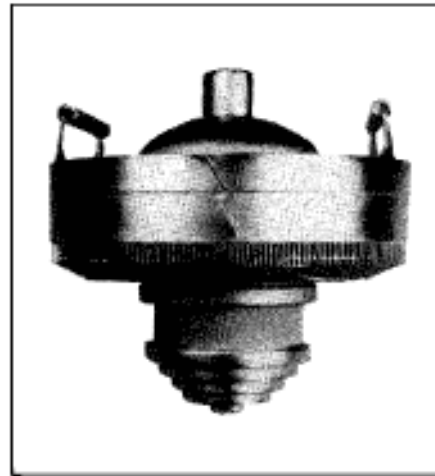

The BURLE 9007 is designed specifically for use in high-gain, high-linearity equipments for VHF-TV and FM service and for communication transmitters to 400 MHz.

In VHF-TV service at 216 MHz, the 9007 can deliver up to a full 33 kilowatt peak sync output with 6.3 MHz bandwidth and 14 dB gain.

Rated for full input to 400 MHz, the tube is easily circuited to this frequency. The terminals are coaxial for operation in the TEM mode and the radiator location avoids restricting the resonant cavity circuits in VHF operation. This assures high gain-bandwidth products for the full VHF-TV band. In addition, it is well suited for other applications such as single sideband, CW or pulsed RF, modulator service, and translator service.

Its sturdy, coaxial CERMOLox<sup>®</sup> construction and thoriated-tungsten mesh filament minimize tube inductances and feed-thru capacitances. They make possible the use of simple, economical, broadband circuit techniques in VHF operation. Additional information of a general nature applicable to tubes of this type is given in the following publications:

TP-105 Application Guide for Power Tubes  
AN-4020 Screen-Grid Current, Loading and Bleeder  
AN-4865 Handling and Operating Considerations

AN-4869 Application Guide for Forced Air Cooling  
AN-4872 Broadcast-Tube Handling and Installation

Close attention to the instructions contained in these publications will assure longer tube life, safer operation, less equipment downtime and fewer tube handling accidents.

### General Data

#### Electrical:

Filamentary Cathode, Thoriated-Tungsten Mesh Type:

Voltage <sup>a</sup> (AC or DC).....	9.5	typ.	V
	10.0	max.	V
Current: <sup>b</sup>			
Typical.....	147		A
Instantaneous peak value during startups <sup>c</sup> .....	300	max.	A
Cold resistance.....	0.01		ohms
Minimum heating time			See Note C
Mu-Factor <sup>d</sup> (Grid No 2 to Grid No.1)...	12		
Direct interelectrode Capacitances			
Grid No.1 to plate <sup>e</sup> .....	.04	max.	pF
Grid No.1 to filament.....	115		pF
Plate to filament <sup>e</sup> .....	0.2	max.	pF
Grid No.1 to grid No.2.....	110		pF
Grid No. 2 to plate.....	18		pF
Grid No. 2 to filament <sup>e</sup> .....	4	max.	pF

---

Formerly Type A3021

**Mechanical:**

Operating Attitude.....	Vertical, either end up
Overall Length (Max.).....	8.5 in
Greatest Diameter (Max.).....	8.4 in
Radiator.....	Integral part of tube
Weight (Approx. ....)	20 lbs

**Thermal:**

Seal Temperature <sup>f</sup> .....	250 max.	°C
Plate, Grid-No.2, Grid-No 1 Cathode-Filament, and Filament)		
Average Plate-Core Temperature <sup>f, g, ..</sup>	250 Max.	°C

**RF Power Amplifier-Class B Television Service<sup>h</sup>**

Synchronizing-level conditions per tube unless otherwise specified.

**Maximum CCS Ratings, Absolute-Maximum Values:**

DC Plate Voltage <sup>i</sup> .....	13,000 max.	V
DC Grid-No.2 Voltage <sup>k</sup> .....	2000 max.	V
DC Grid-No.1 Voltage <sup>q</sup> .....	-600 max.	V
DC Plate Current .....	7 max.	A
Plate Dissipation.....	See Note m	
Grid-No.2 Input.....	250 max.	W
Grid-No 1 Input.....	150 max.	W

**Calculated CCS Operation**

In a cathode-drive circuit at 216 MHz and bandwidth of 6.3 MHz<sup>r</sup>

DC Plate Voltage.....	8400	V
DC Grid-No. 2 Voltage.....	1500	V
DC Grid-No. 1 Voltage <sup>n</sup> .....	-190	V
Zero-Signal DC Plate Current.....	1.5	A
DC Plate Current:		
Synchronizing level.....	6.5	A
Blanking level.....	4.9	A
DC Grid-No.2 Current:		
Synchronizing level.....	0.18	A
Blanking level.....	0.03	A
DC Grid-No. 1 Current:		
Synchronizing level.....	0.22	A
Blanking level.....	0.01	A
Driver Power Output: <sup>p</sup>		
Synchronizing level.....	1250	W
Blanking level.....	750	W
Useful Power Output:		
Synchronizing level.....	33,000	W
Blanking level.....	18,500	W
Power Gain, Including Circuit Losses.....	14.2	dB

a Measured at the tube terminals. For accurate data the ac filament voltage should be measured using an accurate RMS type meter such as an iron-vane or the thermocouple type meter. The DC voltage should be measured using a high input impedance type meter.

For high-current, low-voltage filaments such as are used in this tube, it is recommended that the filament current be monitored since very small changes in resistance can produce misleading changes in voltage. For maximum life, the filament power should be regulated at the lowest value that will give stable performance. For these applications where hum is a critical consideration, dc filament or hum bucking circuits are recommended. See also Application Note AN-4865.

b It is recommended that additional current be available to

allow for both product variation and the normal reduction of filament resistance with life. Thus the filament supply adjustment should be designed for capability of 167 amperes at 9.5 volts. A minimum setting is 8.85 volts.

c Recommended starting procedure for maximum stability and longest life.

1. Standard: Filament heating time of 120 seconds followed by grid-No. 1, plate, grid-No. 2, and rf drive.

2. Emergency 1: (Power Interruption of 15 seconds or less) The tube may be brought back on the air two seconds after power restoration. Precautions must be taken so that neither the filament surge current limit nor the maximum filament voltage rating is exceeded. The sequence of voltage application after filament warm-up is as follows: grid-No.1, plate, grid-No. 2, and rf drive.

3. Emergency 2: (Power Interruption of greater than 15 seconds) The tube may be brought back on the air four seconds after power restoration. Precautions must be taken so that neither the filament surge current limit nor the maximum filament voltage rating is exceeded. In order to insure that the tube does not operate in excess of typical conditions, control of the rf drive level will be required until tube temperature stability is achieved and special consideration must be given to the design of grid-No.1 circuitry. Application Engineering assistance is available from BURLE. The sequence of voltage application after filament warm-up is as follows: grid-No.1, plate, grid-No.2, and rf drive.

d For plate voltage = 2000 V, grid-No.2 voltage = 1250 V, and plate current = 15 A.

e As measured with a special, shielded adapter. The value noted is the true tube internal capacitance and does not include external circuit or stray capacitance.

f See Dimensional Outline for Temperature Measurement Points. For good contact-finger life, a maximum temperature of 180 °C at the terminal is recommended when using commercially-available beryllium-copper socket contacts.

g The value of 250 °C is the average of 3 readings taken 120° apart around the anode core. No one reading may exceed 275 °C.

h See Class of Service TP-105.

j See Power Supplies TP-105.

The maximum voltage ratings must be modified for operation at altitudes higher than sea level and for temperatures in excess of 20 °C in accordance with the curves of **Figure 1**. For altitude derating of the plate voltage, use the voltage difference between plate and grid No. 2.

The maximum fault energy that can be dissipated within the tube is approximately 100 joules. Therefore, the energy available for a high-voltage arc or fault must be limited to this value by means of current limiting resistors or fault-protection circuitry such as spark gaps and electronic "crow bars." This is especially important where high, stored energy and large capacitors are used. In typical 30 kW TV transmitters, the series resistors used are:

Plate - 10 ohms, Grid No.2 - 30 to 50 ohms, Grid No.1 - 50 ohms. For additional information see TP-105, Application Guide for Power Tubes."

- k See TP-105 and AN-4020. Protection devices such as spark gaps should be used.
- M Permitted plate dissipation is a function of cooling. For specific ratings see Forced Air Cooling information in this data sheet.
- n Adjusted for specified zero-signal dc plate current.
- p Driver power output represents circuit losses in the driver output circuit and the grid input circuit in addition to the power necessary to drive the tube.
- q See TP-105. Protection devices such as spark gaps or positive clamping diodes should be used.
- r The bandwidth of 6.3 MHz is calculated at the -0.72 dB power points of a double-tuned output circuit using two times the tube output capacity and a damping factor of  $\sqrt{1.5}$  as shown in **Figure 2**.
- s Use an oscilloscope in system checkout. Systems such as auto-transformers, step transformers, shortable limiting resistors, saturable reactors, or combinations thereof must be used.

### Warning - Personal Safety Hazards

**Electrical Shock-** Operating voltages applied to this device present a shock hazard.

**X-Ray Warning** - This device in operation produces x-rays which can constitute a health hazard unless the device is adequately shielded for radiation.

**RF Radiation** - This device in operation produces rf radiation which may be harmful to personnel.

## Operating Considerations

### Safety Precautions

Protection circuits serve a threefold purpose: safety of personnel, protection of the tube in the event of abnormal circuit operation, and protection of the tube circuits in the event of abnormal tube operation.

Power tubes require mechanical protective devices such as interlocks, relays, and circuit breakers. Circuit breakers alone may not provide adequate protection in certain power-tube circuits when the power-supply filter, modulator, or pulse-forming network stores much energy. Additional protection may be achieved by the use of high-speed electronic circuits to bypass the fault current until mechanical circuit breakers are opened. These circuits may employ a controlled gas tube, such as a thyratron or ignitron, depending on the amount of energy to be handled.

Great care should be taken during the adjustment of circuits. The tube and its associated apparatus, especially all parts which may be at high potential above ground, should be housed in a protective enclosure. The protective housing should be designed with interlocks so that personnel can not possibly come in contact with any high-potential point in the

electrical system. The interlock devices should function to break the primary circuit of the high-voltage supplies and discharge high-voltage capacitors when any gate or door on the protective housing is opened, and should prevent the closing of this primary circuit until the door is again locked.

The screen circuit requires special attention because the heating power of the current and voltage on this electrode is not the algebraic product of the current and voltage elements as observed at the terminal. For analysis of the circuit, review AN-4020.

A time-delay relay must be provided in the grid-No.1 supply circuit to delay application of this voltage until the filament has reached normal operating temperature.

An interlocking relay system should be provided to prevent application of plate voltage prior to the application of sufficient bias voltage otherwise, with insufficient bias, the resultant high plate current may cause excessive plate dissipation with consequent damage to the tube. RF load shorts or other causes of high output VSWR may also cause high dissipations, excessive voltage gradients, or insulator flashover. The load VSWR should be monitored and the detected signal used to actuate the interlock system to remove the plate voltage in less than 10 milliseconds after the fault occurs.

### Filament-Voltage Adjustment

The life of the filament can be conserved by adjusting to the lowest filament supply voltage that will give the desired performance. Follow the filament voltage adjustment procedure below.

1. Before the application of any other voltages to a new tube, the filament voltage should be adjusted to 9.5 volts at the tube socket. A true RMS voltmeter should be used for accurate measurement. It may be more convenient to make the measurement at other contacts in the equipment, but the value will be higher because of increased impedance such as wire loss or contact resistance.
2. Apply voltages and adjust tuning controls as necessary for proper operation as described in the appropriate instruction manual.
3. Reduce the filament voltage in 0.1 -volt increments - repeating the procedures in Steps 1 and 2 - until performance degradation such as a decrease in plate current or power output is noted. Then increase the heater voltage 0.2 volt above this point. Typically depending upon the application, this voltage will be in the range of 9.2 to 9.5 volts.

During life when evidence is observed that a tube is becoming emission limited, increasing the filament voltage may extend the useful life of the tube. However, never increase filament voltage to compensate for a decrease in other circuit parameters such as if drive or video modulating voltage!

### **Forced Air Cooling**

Cooling air flow is necessary to limit the anode-core and terminal-seal temperatures to values that will assure long reliable life. A sufficient quantity of air should be directed past each of these terminals so that its temperature does not approach the absolute-maximum limit. The absolute-maximum temperature rating of the anode is 275 °C with a maximum average temperature around the anode of 250 °C. It is recommended that a safety factor of 25° to 50° be applied, to compensate for all probable system and component variations throughout life.

The cooling air must be delivered by the blower through the radiator and at the terminal seals during the application of power and for a minimum of three minutes after the power has been removed.

To Cathode-Filament and Filament Terminals - A sufficient quantity of air should be blown directly at these terminals so that their temperature does not approach the absolute-maximum limit of 250 °C. A value of at least 60 cfm is recommended.

The Cooling Characteristic Curve indicates the air flow and pressure requirements of a system sufficient to limit the core temperature to specific values for various levels of plate dissipation.

Incoming air is at Standard Temperature and Pressure (STP) (22.5 °C and 760 mm Hg). Pressure drop values are for the anode only and do not include any losses which may occur with specific sockets or cavities. When the tube base is not directly in the anode cooling air stream, special provisions must be made for separate base cooling.

Because the cooling capacity of air varies with its density, factors must be applied to the air flow to compensate for operation at altitude or in high temperature environments.

During Standby Operation - Cooling air is required when only the filament voltage is applied to the tube.

For further information on forced air cooling, see TP-105 and also AN-4869 "Application Guide for Forced Air Cooling of Power Tubes".

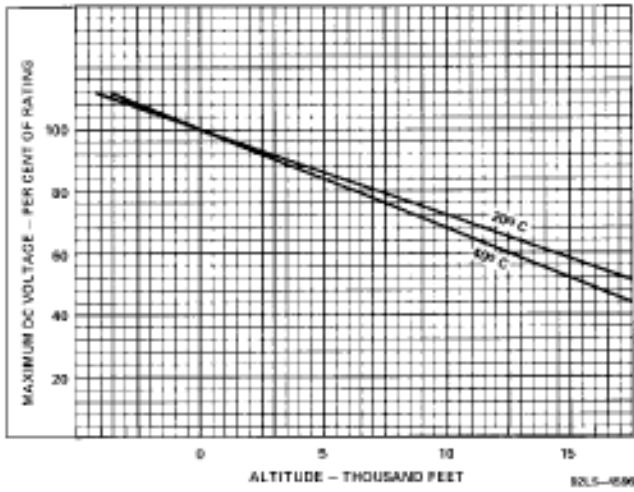

Figure 1 - Maximum DC Voltage With Respect to Altitude

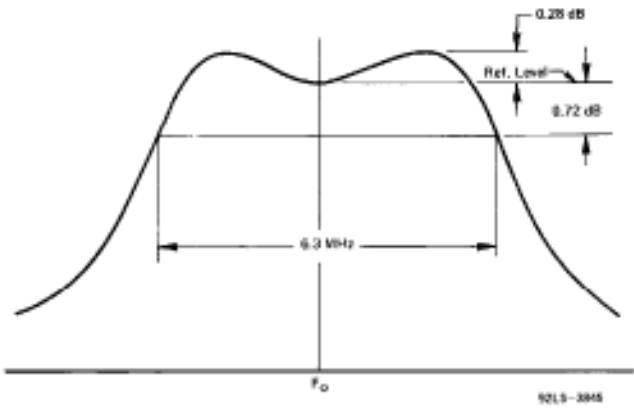

Figure 2 - Bandwidth Characteristics

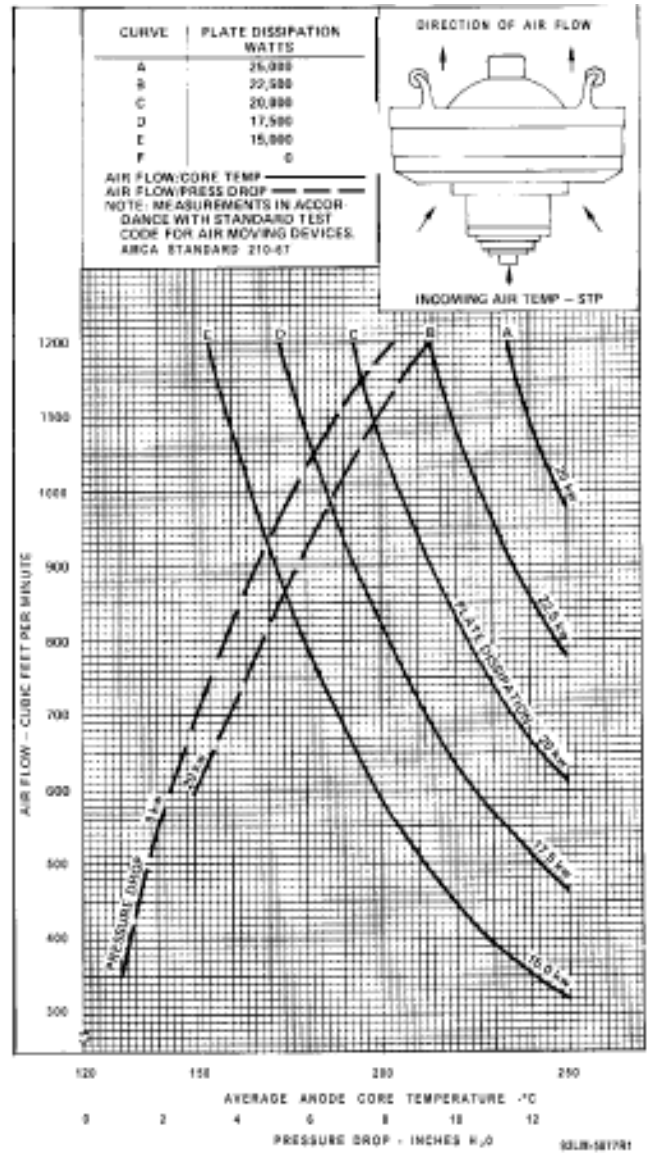

Figure 3 - Typical Cooling Characteristics

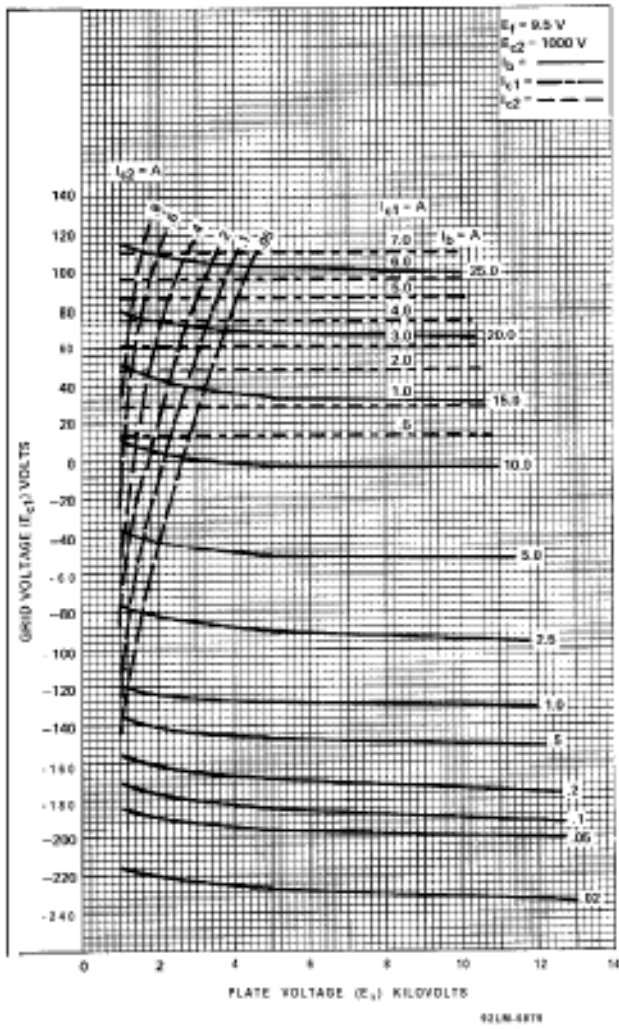

Figure 4 - Typical Constant Current Tube Characteristics @  $E_{c2} = 1000$  V

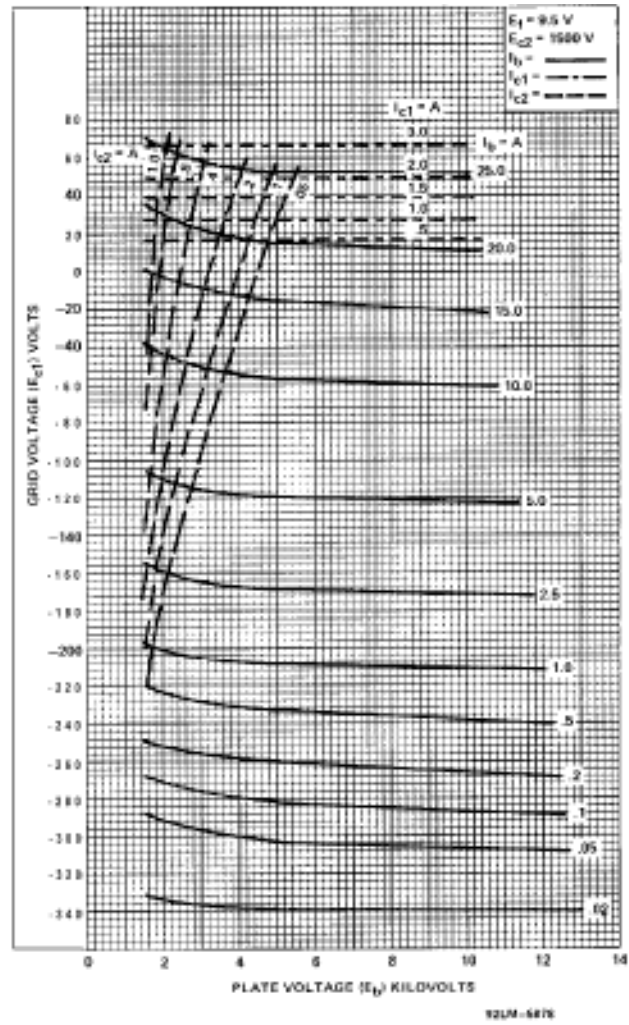
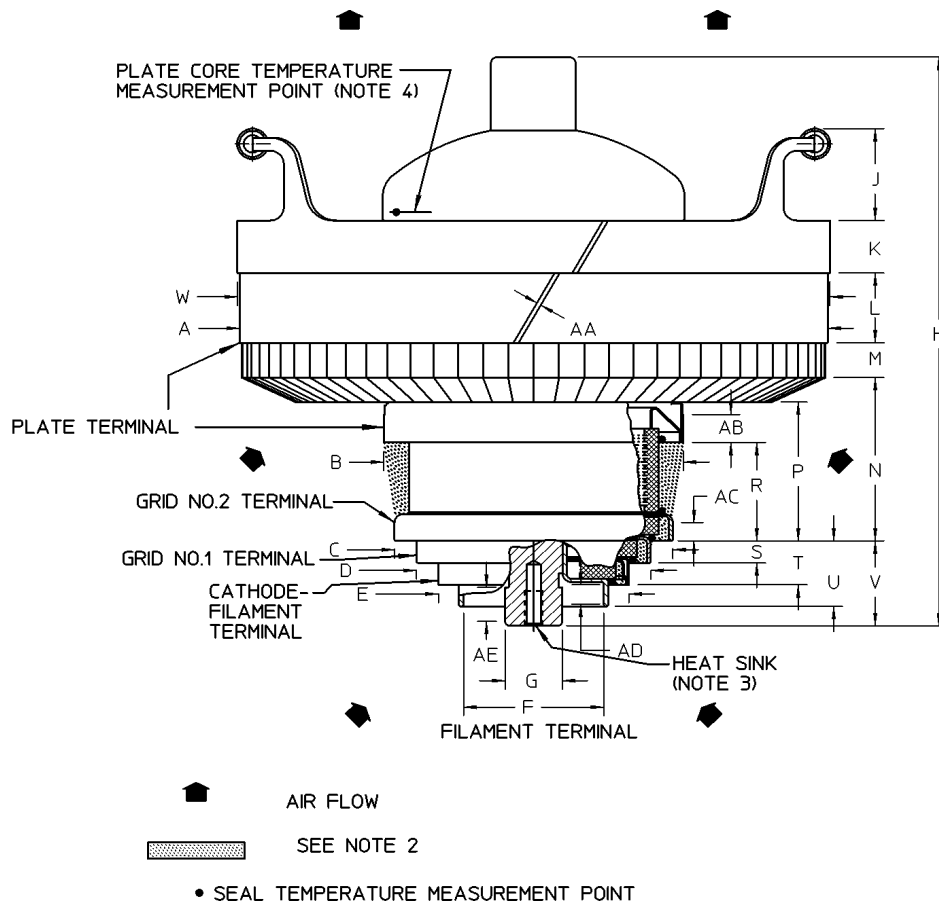

Figure 5- Typical Constant Current Tube Characteristics @  $E_{c2} = 1500$  V



**Tabulated Dimensions\***

Dimensions	Inches	Millimeters	Notes
A Dia.	8.250 ± .035	209.55 ± .89	1,5
B Dia.	4.188 ± .020	106.38 ± .51	1,5
C Dia.	3.915 ± .015	99.44 ± .38	1,5
D Dia.	3.315 ± .015	84.20 ± .38	1,5
E Dia.	2.696 ± .015	68.48 ± .38	1,5
F Dia.	1.960 ± .015	49.78 ± .38	1,5
G Dia.	0.810 max.	20.57 max.	1,5
H	8.500 max.	215.90 max.	
J	1.310 ref.	33.27 ref.	
K	0.750 ref.	19.05 ref.	
L	1.00 0± .050	25.40 ± 1.3	
M	0.540 ref.	13.72 ref.	
N	2.150 ± .050	54.60 ± 1.3	
P	1.775 min.	45.09 min.	
R	1.420 ± .030	36.07 ± .76	
S	0.330 ± .030	8.38 ± .76	
T	0.650 ± .040	16.51 ± 1.0	
U	0.960 ± .050	24.4 ± 1.3	
V	1.200 ref.	30.48 ref.	
W	8.314 ± .035	211.18 ± .89	
AA	0.062 ref.	1.51 ref.	
AB	0.265 min.	6.73 min.	1
AC	0.265 min.	6.73 min.	1
AD	0.265 min.	6.73 min.	1
AE	0.450 min.	11.43 min.	1

**Figure 6 - Dimensional Outline**

- Note 1** - The diameter of each terminal is maintained only over the indicated minimum length of its contact surface.
- Note 2** - Keep all stippled regions clear. In general do not allow contacts to protrude into these annular regions. If special connectors are required which may intrude on these regions, contact BURLE Power Tube Application Engineering, Lancaster, PA 17601-5688.
- Note 3** - Tapped 1/4 -20 NC x 0.5" (12.7 mm) deep. May be used for attaching additional heat sink for seal temperature control if required.
- Note 4** - Plate core temperature measurement point is located on the plate itself and not at the fins.
- Note 5** - With the plate terminal and the cathode-filament terminal used as reference, the other terminals will measure less than 0.040" (1.02 mm) total indicator run-out (TIR).

\* Dimensions are in inches unless otherwise stated. Metric dimensions are derived from the basic inch dimensions (One inch = 25.4 millimeters).