

7835/V1 Power Tube

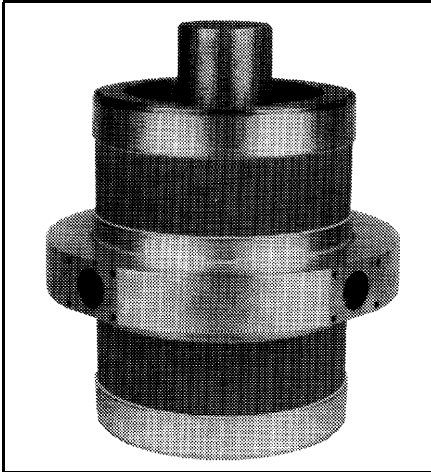

VHF Large Power Triode

- Double Ended
- Frequencies to 400 MHz
- Short Pulse to 7.5 MW
- Long Pulse to 4 MW
- Liquid Cooled
- Coaxial Electrodes

The BURLE 7835 is a water cooled, large-power triode designed and tested specifically for use as an RF power amplifier in pulse service to 400 MHz. As a plate-pulsed amplifier the 7835 is well suited for use in long range search radar, pulsed transmission in communication service and particle accelerator service.

As a plate-pulsed RF amplifier at 250 MHz in a cathode drive circuit, with a 25 microsecond pulse at 0.6 percent duty, the 7835 can deliver a useful peak power of 7.5 megawatts. In a similar circuit with a pulse of 2000 microseconds at a duty of 6 percent, it can deliver four megawatts of useful power.

The 7835 features a precisely spaced, cylindrical array of 96 identical triode units each employing a thoriated-tungsten filamentary cathode for high emission, long life and economical operation. The tube employs double ended construction to permit the placement of the active elements at the electrical center of a half-wavelength resonant cavity.

This configuration also allows higher frequency operation than possible with single ended tubes of comparable power capabilities.

Other design features of the 7835 include low-inductance, large-area, RF terminals insulated with low-loss ceramic bushings, relatively low output capacitance, low feedback capacitance and high power gain.

This data sheet gives information unique to the BURLE tube type 7835. General information covering installation and operation of this and other large power tubes is given in "Application Guide for BURLE Power Tubes", TP-105. Close attention to the instructions contained therein will assure longer tube life, safer operation, less equipment downtime and fewer tube handling accidents.

For further information or application assistance on this device contact BURLE Power Tube Application Engineering, Lancaster, PA 17601.

General Data

Electrical

Filamentary Cathode:

Type Multistrand Thoriated Tungsten

Current¹(DC):

Typical operating value 6800 A

Maximum operating value 7000 A

Maximum starting value 2000 A

Voltage(DC):

Typical range to obtain operating current

operating current 3.1 4.2 V

Maximum value 4.65 V

Warm-up time:

Minimum to reach operating current 30 s

Minimum at operating current before
plate voltage is applied 60 s

Direct Interelectrode Capacitance:

Grid to plate 150 pF

Grid to cathode 1600 pF

Plate to cathode < 1.0 pF

Mechanical

Operating Attitude Tube axis vertical, either end up

Maximum Overall Length 431.8 mm (17.00 in)

Maximum Diameter 609.6 mm (24.00 in)

Terminal Connections See Dimensional Outline

Weight:

Uncrated 86 kg (190 lb)

Crated 161 kg (355 lb)

Thermal

Metal Surface Temperature	150	max.	°C
Ceramic Bushing Temperature	150	max.	°C
Water Temp. From Any Outlet	70	max.	°C
Storage Temperature ²	-65	min.	°C
External Gas Pressure (Gauge)	{4.7	max.	kgcm ²
	{ 6.5	max.	psi
Water Pressure at Any Inlet (Gauge)	{6.5	max.	kgcm ²
	{ 9.0	max.	psi

Resistivity of Water at 25 °C:

Plate coolant.....	1.0	min.	megohm cm
Grid & cathode coolant	5.0	min.	megohm cm

Cooling

It is essential that the Thermal Specifications be followed. If the tube is used in a confined space both air and water cooling will be required.

Air Cooling:

In general, forced-air cooling of the ceramic bushings and the adjacent contact areas will be required. Provision should be made for blowing an adequate amount of air across the bushings and contact areas to limit their maximum temperature to specified values.

Water Cooling:

Water cooling is required for the upper and lower grid terminals, the grid-cathode structure and the plate. The water flow must start before application of any voltages and should continue for several minutes after the removal of all voltages. Each water flow should be interlocked with all power supplies to prevent tube damage in case of failure of adequate water flow.

Water Flow

	Typical Flow	Minimum Flow	Pressure Diff.				
	gpm f/s	gpm 1/s	psi kg/cm ²				
To Plate:							
Pdis.50 kW	40	2.5	35	2.2	5.0	0.35	
Pdis. 150 kW	100	6.3	90	5.7	30	2.1	
Pdis.300 kW	160	10.2	150	9.5	45	3.2	
To Upper Grid	3.0	0.19	2.0	0.13	25	1.8	
To Lower Grid	3.0	0.19	2.0	0.13	25	1.8	
To Grid-Cathode	35	2.2	30	1.9	30	2.1	

Rating Schedule

Plate Pulsed Amplifier - Class B

For a maximum "ON" time³ of 2200 microseconds in any 34000 microsecond interval at frequencies up to 300 MHz.

Maximum Ratings, Absolute-Maximum Values

Peak Positive-Pulse Plate Voltage ⁴	40,000	V
Peak Grid Voltage.....	-250	V
Peak Plate Current ⁵	300	A
DC Plate Current	19.5	A
DC Cathode Current ⁵	39	A
Plate Input (Average)	487	kW
Plate Dissipation (Average)	300	kW

Typical Operation

In a cathode-drive circuit, with rectangular wave shape pulses of 2000 microseconds, a duty factor of 6.0% at a frequency of 250 MHz.

Peak Positive-Pulse Plate Voltage ⁴	30,000	V
Peak Grid Voltage ⁶	-100	V
Peak Plate Current	220	A
Peak Cathode Current ⁵	350	A
DC Plate Current	13.2	A
DC Cathode Current ⁵	21.0	A
Peak Drive Power ⁷	150	kW
Useful Power Output.....	4000	kW

(At peak of pulse)

Plate Pulsed Amplifier - Class B

For a maximum "ON" time³ of 25 microseconds in any 2500 microsecond interval at frequencies up to 300 MHz.

Maximum Ratings, Absolute-Maximum Values

Peak Positive-Pulse Plate Voltage ⁴	45,000	V
Peak Grid Voltage	-500	V
Peak Plate Current	325	A
Peak Cathode Current ⁵	500	A
DC Plate Current	3.25	A
DC Cathode Current ⁵	5.5	A
Plate Input (Average)	212	kW
Plate Dissipation (Average)	150	kW

Typical Operation

In a cathode-drive circuit, with rectangular waveshape pulses of 25 microseconds, a duty factor of 0.6 percent, at a frequency of 250 MHz.

Peak Positive-Pulse Plate Voltage	42,000	32,000	V
Peak Grid Voltage	-100		V
Peak Plate Current	300	260	A
Peak Cathode Current ⁵	500	450	A
DC Plate Current.....	1.8	1.6	A
DC Cathode Current ⁵	3.0	2.7	A
Peak Drive Power ⁷	250	200	kW
Useful Power Output	7,500	5,000	kW

(At peak of pulse)

1. See TP-105.
2. Coolant ducts must be free of water. See TP-105.
3. For "Definitions of Terms", see TP-105.
4. The magnitude of any spike on the plate voltage pulse should not exceed its peak value by more than 10% and the duration of any spike should not exceed 5% of the pulse duration.
5. Because the plate and grid pulses are not coincident the peak of average cathode current is the sum of the peak or average plate current plus the peak or average rectified grid current.
6. Preferably obtained from a cathode bias resistor.
7. The driver stage is required to supply tube losses, rf circuit losses and RF power added to the plate circuit. The driver stage must therefore be capable of providing and excess of power above the indicated value to take care of variations in line voltage, components, initial tube characteristic and tube characteristics during life. The RF drive pulse must start before and end after the leading and trailing edges of the plate-to-cathode DC modulated pulse.

General Considerations

It is recommended that the 7835 be tested upon receipt in the equipment in which it is to be used. Recommended "Break-In" treatment is covered in TP 105 and also in a separate Paper entitled "Procedure for installation, RF Processing and operation of the BURLE 7835/V1 high Power Triode. Request both papers from BURLE Power Tube application engineering, Lancaster, PA 17601.

Figure 1 shows a block diagram of the input and output resonant Frequency Tests while Figure 2 and 3 are drawings of the cavities which are attached before testing to frequency limits as follows:

Input-90 to 140MHz
Output - 240 to 280 MHz

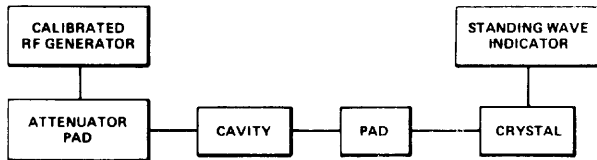
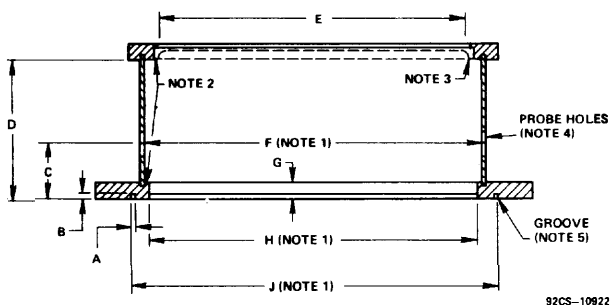

Figure 1 - Block Diagram of Test Circuit and Output Strap-Resonant Frequencies



Tabulated Dimensions*

Dimension	Inches	Millimeters
A	0.152 ± .005	3.86 ± .13
B	0.120 ± .005	3.05 ± .13
C	1.75 ± .02	44.5 ± .5
D	4.686 ± .001 - .000	119.024 + .025 - .000
E Dia.	10.141 Ref.	257.58 Ref.
F Dia	11.013 ± .005	279.73 ± .13
G	0.382 ± .001	9.703 ± .025
H Dia.	10.753 ± .001	273.126 ± .025
J Dia.	12.0 Ref.	304.8 Ref.

Note 1 - Runout on diameters indicated not to exceed 0.002" (0.051 mm).

Note 2 - Juncture must provide good rf electrical contact around its entire circumference, such as by a braze or soft solder connection. Maximum braze or solder fillet not to exceed 0.030" (0.76 mm) radius.

Note 3 - Spring contact ring, Catalog No.97-135 as made by Instrument Specialties Co., Little Falls, NJ 07424.

Note 4 - Two "Probe Holes" each 3/4" (19 mm) diameter.

Note 5 - Groove for braid contact ring, Catalog No.10-118 as made by Electronics Division, Metal Textile Corp., Roselle, NJ 07203. The braid must assure continuous contact

Figure 2 - Full Section View of Input Cavity Required for Input Strap-Resonant Frequency Test

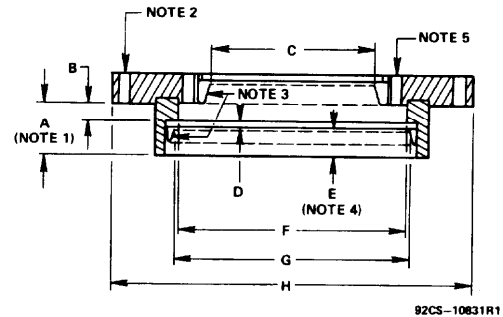

Tabulated Dimensions*

Dimension	Inches	Millimeters
A _c	1.55 ± .02	39.4 ± .5
A _f	1.13 ± .02	28.7 ± .5
B	0.40 Ref.	10.2 Ref.
C Dia	3.598 Ref.	91.4 Ref.
D	0.120 ± .002	3.05 ± .05
E _c	1.03 ± .02	26.2 ± .5
E _f	0.61 ± .02	15.5 ± .5
F Dia	4.825 ± .005	122.56 ± .13
G Dia	4.935 Ref.	125.35 Ref.
H Dia	7.63 ± .03	193.8 ± .8

Note 1 - Dimension A_c is the measurement for the cavity used at the upper-rf-cathode-terminal end. Dimension A_f is the measurement for the cavity used at the filament terminal end.

Note 2 - Eight holes used for extracting cavity.

Note 3 - Spring contact ring, Catalog No.97-135 as made by Instrument Specialties Co., Little Falls, NJ 07424.

Note 4 - Dimension E_c is the measurement for the cavity used at the upper-rf-cathode-terminal end. Dimension E_f is the measurement for the cavity used at the filament terminal end.

Note 5 - Two "Probe Holes".

Figure 3 - Full Section View of Output Cavity Required for Output Strap-Resonant Frequency Test

Mounting

The mounting used for the 7835 should hold the tube vertically with either end up. The entire weight of the tube should be supported by the upper or lower mounting surfaces (See Dimensional Outline)

Connections

Because of the low-voltage, high-current filament, it is recommended that the filament connectors be kept short to minimize voltage drop. The use of coaxial filament connectors is recommended. The connector for the coaxial terminals of the filament should be of the coil-spring, pressure-contact type (See Detail of Filament Terminals). The filament connectors should make firm, large-surface contact. Caution should be exercised when assembling or disassembling the filament connectors so that the filament terminals are not loosened. To avoid loosening of filament terminals, always rotate connectors clockwise when viewing tube from filament-terminals end, both for assembly and disassembly of filament connectors.

* Basic dimensions are in inches. Metric dimensions are derived from the basic inch dimensions and are based on one inch = 25.4 mm.

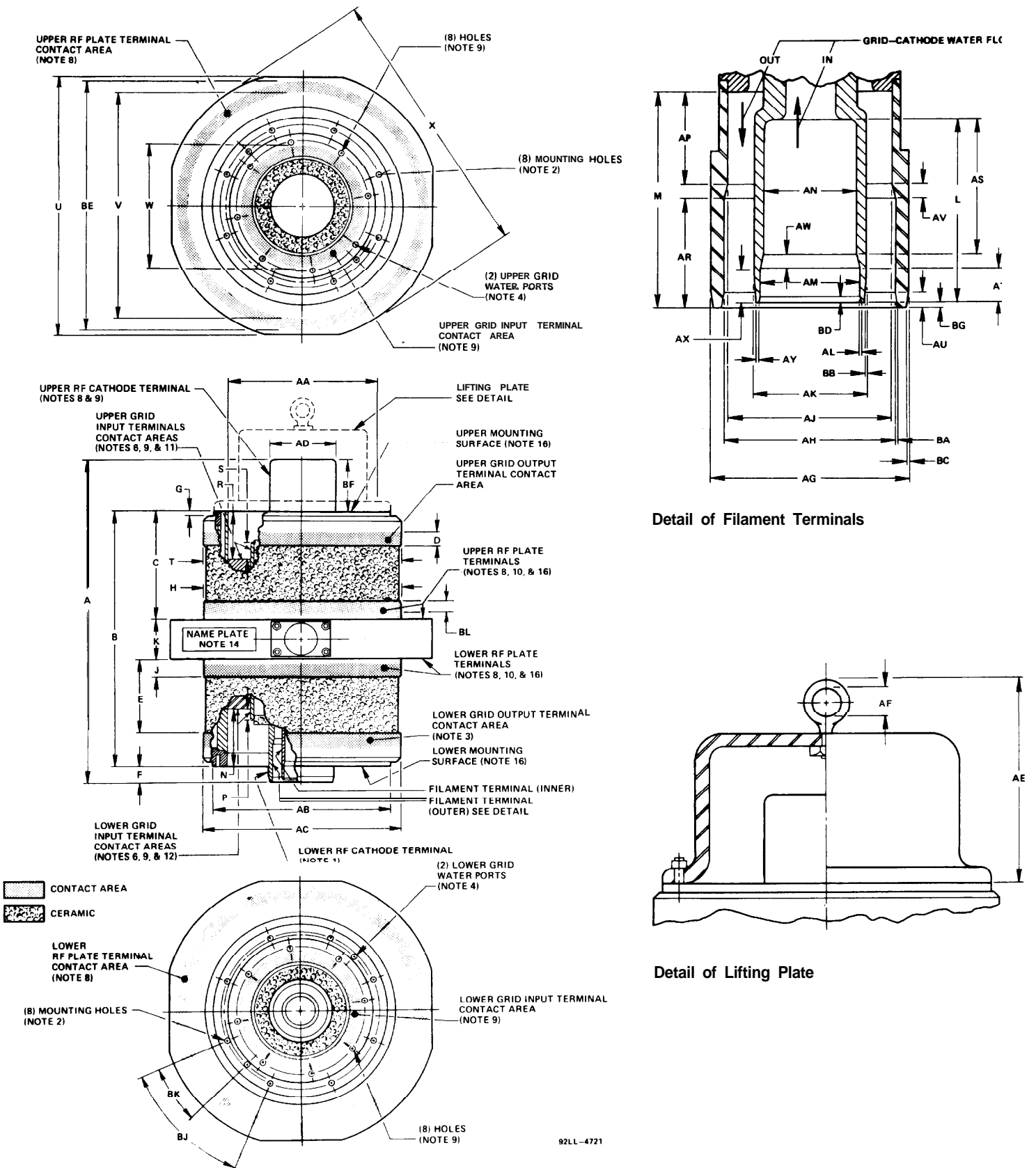

Figure 4 - Dimensional Outline

Notes for Dimensional Outline

	LTR	Inches*		Millimeters* (Note 15)	
		Minimum	Maximum	Minimum	Maximum
1. DC filament current must not be permitted to flow in the upper rf-cathode terminal. The internal structure of the tube is such that the potential of the upper rf-cathode terminal differs from that of the lower rf-cathode terminal by the amount of the DC filament voltage. The circuit designer should take care, therefore to avoid an external DC path between these two cathode terminals.	A		17.00	—	431.8
	B		13.50	—	342.9
	D	0.75	—	19.1	—
	F	0.52	0.76	13.2	19.3
	G	—	0.25	—	6.3
2. The tube may be conveniently handled and moved by means of the lifting plate which may be attached to either mounting surface. The lifting plate should be removed prior to operating the tube. The mounting surface holes are .250"-20 UNC-1B x 0.25" (6.35 mm) minimum depth, and equally spaced on a bolt circle of 8.75" (222.25 mm) diameter.	H Dia.	—	10.30	—	261.6
	J	0.85	0.96	21.6	24.4
	K	2.07	2.15	52.58	54.61
	L	3.34	3.41	84.84	86.87
	M	3.97	4.03	100.84	102.36
3. Along the tapered contact length D, dimension AC will increase from a minimum diameter of 10.15" (257.8 mm) [average diameter at this point is 10.20" (259.1 mm)] to a maximum diameter at T 10.30" (261.6 mm) [average diameter at T is 10.25" (260.4 mm)]. The maximum diameter T is at the end toward the ceramic.	N	2.92	3.03	74.2	76.9
	P	0.50	—	12.7	—
	R	2.52	2.63	64.0	66.8
	S	0.93	—	23.62	—
	U	13.55	13.80	344.2	350.5
4. The direction of flow, IN or OUT, is stamped at the side of each port. The ports are 0.250" ± 0.010" (6.35 ± .25 mm) diameter located 180° ± 1/2° apart on a circle of 8.25" (209.55 mm) diameter. The upper grid water ports are located on the mounting surface in the quadrant counter-clockwise from each plate water inlet, as viewed from the upper rf-cathode terminal end. The lower grid water ports are located on the mounting surface in the same quadrant as viewed from upper rf-cathode terminal end.	V Dia.	—	12.00	—	304.8
	W Dia.	6.75	—	171.5	—
	X Dia.	13.85	14.10	351.8	358.1
	Y Dia.		5.02	—	127.5
	AA Dia.	7.63	7.87	193.8	199.9
	AB Dia.	9.40	9.64	238.8	244.8
	AE		6.00	—	152.4
	AF Dia.	0.875	—	22.23	—
6. Along the lengths S and P, the contact areas are tapered, increasing diameter "Y" from a 4.90" (124.46 mm) average [4.88" (123.95 mm) minimum] at the recessed end to a 4.96" (125.96 mm) average [5.02 (127.5 mm) maximum] at the other end.	AK Dia.	1.98	2.02	50.29	51.30
	AP	1.63	1.67	41.40	42.42
	AR	2.090	2.110	53.09	53.59
	AS	2.490	2.510	63.25	63.75
	AT	0.615	0.635	15.62	16.13
Circuit contacts should be made only over maximum length D 0.75" (19.1 mm) of the designated upper and lower output terminal contact areas as measured nearest the ceramic.	BE Dia.	13.40	—	340.4	—
	BF	2.33	2.57	59.2	65.2
8. Contact of the upper and lower rf plate terminal contact areas should be made at a diameter less than 13.40" (340.4 mm) or greater than 12.00" (304.8 mm).	BG		0.10	—	2.5
	BK	21.5°	23.5°	—	—
	BL	0.63	—	16.0	—
9. Contact of the upper and lower grid input terminal contact areas should be made at a diameter less than 6.75" (171.45 mm) The holes located outside the contact area are .250"-20 UNC-1B x 0.25" (6.35 mm) minimum depth, equally spaced on a bolt circle of 7.25" (184.15 mm) diameter.	Quality Conformance Inspection, Part 1:				
	C	5.51	5.68	140.0	144.2
	E	3.79	3.96	96.3	100.5
	T Dia.	—	10.30	—	261.6
10. Circuit contact should be made at any point along the length BL 0.63" (16.0 mm) of designated upper and lower rf-plate terminals as measured nearest the ceramic.	AC Dia.	10.12	—	257.1	—
	AD Dia.	3.59	3.65	91.19	92.71
	AG Dia.	3.59	3.65	91.19	92.71
11. Circuit contact should be made at any point along the length S 0.93" (23.62 mm) of the designated upper grid input terminal.	AH Dia.	3.121	3.131	79.28	79.52
	AJ Dia.	2.997	3.007	76.13	76.37
12. Circuit contact should be made at any point along the length P 0.50" (12.7 mm) of the designated lower grid input terminal.	AM Dia.	1.745	1.755	44.33	44.57
	AN Dia.	1.695	1.705	43.05	43.30
13. Dimension applies to both ends of tube.	Reference Dimensions:				
14. Name plate may be located between any two adjacent water connections.	AL		.03		.76
	AU		.28		7.11
15. Metric equivalents are given for general information only and are based on 1 inch = 25.4 mm.	AV		.25		6.35
	AW		.25		6.35
16. The tube should be operated vertically with either end up. The entire weight of the tube should be supported by the rf plate terminal or by either mounting surface. Never support the tube by the filament terminals or by the upper rf-cathode terminal. Care should be taken to avoid distortion or damage to the filament terminals by bumping or improperly fitting connectors. Total indicator run-out between terminals will not exceed 0.10" (2.54 mm).	AX		.50		12.7
	AY		.06		1.52
	BA		.04		1.02
	BB		.03		.76
	BC		.04		1.02
	BD		.10		2.5
	BJ		45°		

*Unless otherwise specified.